

# MODELING SIMULATION AND ANALYSIS OF PV CELL BOOST CONVERTER FED INDUCTION MOTOR DRIVE WITH CLOSED LOOP SPEED CONTROL

**K. Krishna Reddy \*, D.V.Kiran \*\*, B.Gurappa\*\*\* and A.Nagaraju\*\*\*\***

\* \*\* \*\*\* Department of EEE, Mother Theresa Institute of Engineering and Technology, AP, India  
\*\*\*\* Department of EEE, Gitam University, AP, India

**ABSTRACT:** This paper presents photo voltaic panel with a boost converter and three phase inverter whose output is fed to induction motor based drive system, which is mainly used for the purpose of village agricultural water pumps. To step up the output of the solar panel and to match the input voltage of motor load a boost converter is used. PV array is progressively more employed for water pumping system. In this paper, a boost converter to step up the input voltage of the inverter interjected among the PV array and single-phase induction motor is developed. The replica was put into practice using MATLAB/Simulink with SPWM controlled inverter representation. The comprehensive modeling of the components of proposed scheme has been taken up. The developed boost converter steps up the voltage created by the PV array to a value which is appropriate to run a single-phase induction motor. The inverter converts DC to AC is restricted by using sinusoidal pulse width modulation (SPWM) technique.

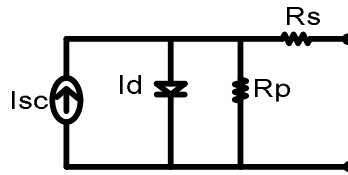
**KEYWORDS:** Boost converter, Induction motor drive, Closed loop speed control, Photo voltaic array.

## INTRODUCTION

The photovoltaic energy system has the advantages of absence of fuel cost, no environmental impacts, low maintenance and lack of noise and also it is a kind of renewable energy system. So it is becoming popular in the recent years, as a resource of energy. Modeling and simulation of PV array based on circuit model and mathematical equations are proposed [5]. As the photovoltaic (PV) cell exhibits the nonlinear behavior, while matching the load to the photovoltaic modules, DC-DC power converters are needed. There are several converter configurations such as Buck, Boost, Buck-Boost, SEPIC, ĆUK, Fly-back, etc. Buck and Boost configurations can decrease and increase the output voltages respectively, while the others can do both functions. Buck, Boost, Buck Boost converters as interface circuits are proposed [1,3]. When the solar insolation and temperature is varying, the PV module output power is also getting changed. But to obtain the maximum efficiency of PV module it must be operated at maximum power point. So it is necessary to operate the PV module at its maximum power point for all irradiance and temperature conditions. SPWM voltage-source inverters (VSI) are far and wide utilized in ac motor drive applications and at a lesser quantity in controlled rectifier applications as a means of dc to ac power alteration devices, about three quarters of a century of advancement in the power electronics field, and concerning half a century of evolution in the microelectronics/macro-electronics and control fields are inherited in the state of the art SPWM-VSI converters. Typically occurring at different time frames, the breakthroughs experienced in each field have strongly and positively influenced the evolution of today's various types of cost effective, efficient, compact, and reliable high performance SPWM-VSI converters. Since they involve various disciplines of engineering and there has always been a strong demand for them in the market, SPWM-VSI converters have continuously drawn the attention of many researchers all around the world. Therefore, in parallel with this progress, a substantial amount of literature relating to electric converters has been accumulated. In particular, the literature involving the SPWM methods boosting of input voltage.

**PHOTOVOLTAIC**

Here is showing the PV module practical equivalent circuit in fig.1 [2].



**Figure 1.** PV module Equivalent circuit

In the corresponding circuit, the current source stands for the current engendered by light photons and its output is stable under constant temperature and constant irradiance. The diode shunted with the current source decides the I-V characteristics of PV module. There is a series of resistance in a current path through the semiconductor material, the metal grid, contacts, and a current collecting bus. These resistive losses are bumped mutually as a series resistor ( $R_s$ ). Its consequence becomes very remarkable in a PV module. The loss allied with a small leakage of current through a resistive path in parallel with the intrinsic device is characterized by a parallel resistor ( $R_p$ ). Its result is much fewer important in a PV module balanced to the series resistance, and it will merely turn out to be perceptible when a number of PV modules are coupled in parallel for a larger system. The distinctive equation which symbolizes the I-V characteristic of a practical photovoltaic module is specified below [9].

$$I = I_{pv} - I_o \left[ \exp\left(\frac{V+IR_s}{V_t N}\right) - 1 \right] - \frac{V+IR_s}{R_p} \tag{1}$$

Where  $V$  and  $I$  are the voltage and currents of PV cell respectively,  $I_{pv}$  is the photovoltaic current,  $I_o$  is the reverse saturation current of diode,  $V_t = NskT/q$  is the thermal voltage of the array with  $N_s$  cells connected in series,  $k$  is the Boltzmann constant ( $1.3806 \times 10^{-23} \text{J/K}$ ),  $T$  is the temperature of the p-n junction,  $q$  is the electron charge and  $n$  is the diode ideality constant.  $I_{pv}$  and  $I_o$  are given as follows [9].

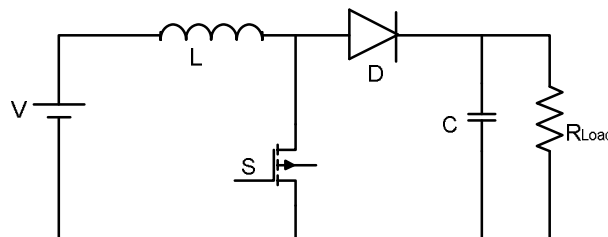
$$I_{pv} = \{ [1 + a(T - T_{ref})] I_{sc} \} \left[ \frac{G}{1000} \right] \tag{2}$$

$$I_o = I_o(T_{ref}) \left[ \frac{T}{T_{ref}} \right]^{\frac{3}{n_e} \frac{qE_g}{nk}} \left[ \frac{1}{T_{ref}} - \frac{1}{T} \right] \tag{3}$$

Where “ $a$ ” is temperature coefficient of  $I_{sc}$ ,  $G$  is the given irradiance in  $\text{W/m}^2$  and  $E_g$  is the band gap energy ( $1.16\text{eV}$  for Si).

**DC-DC (BOOST) CONVERTER**

A boost converter is a specific type of dc-dc power electronic converter whose goal is to efficiently step up DC voltage to a higher level with minimal ripple.



**Figure 2.** Boost converter

The boost is a popular non-isolated power stage topology, sometimes called a step-up power stage. Power supply designers choose the boost power stage because the required output is always higher than the input voltage. The input current for a boost power stage is continuous, or non-pulsating, because the output diode conducts only during a portion

of the switching cycle. The output capacitor supplies the entire load current for the rest of the switching cycle. Figure 2 shows a simplified schematic of the boost power stage. Inductor  $L$  and capacitor  $C$  make up the effective output filter. Resistor  $R$  Load represents the load seen by the power supply output.

### Circuit Operation

A simplified, qualitative way to visualize the circuit operation is to consider the inductor as an energy storage element. When  $SW$  is ON, energy is added to the inductor. When  $SW$  is OFF, the inductor and the input voltage source deliver energy to the output capacitor and load. The output voltage is controlled by setting the on time of  $SW$ . For example, by increasing the on time of  $SW$ , the amount of energy delivered to the inductor is increased. More energy is then delivered to the output during the off time of  $SW$  resulting in an increase in the output voltage. When the switch is ON for a time duration  $DT$ , the switch conducts, the inductor stores energy. This results in a positive voltage  $V_L = V_{in} \max$  across the inductor. This voltage causes a linear increase in the inductor current  $I_L$ . Figure 3 shows a simplified schematic of the boost converter during ON time.

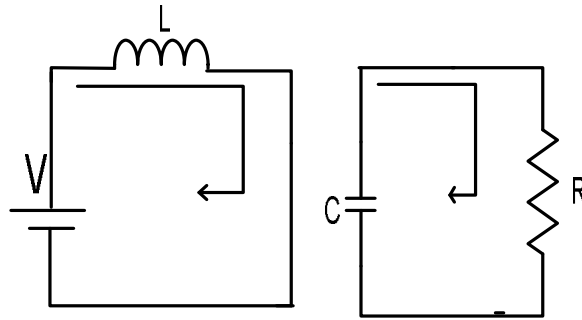


Figure 3. Boost Converter during Switch ON time

When the switch is turned OFF, because of the inductive energy storage, the input supply voltage and the energy stored in the inductor adds and delivers to the load. This current now flows through the diode, and  $V_{out} = V_L + V_{in}$  for time duration  $(1-D) T$  until the switch is turned on again. Figure 4 shows a simplified schematic of the boost converter during OFF time. Therefore, a converter and its control should be designed based on both modes of operation. However, for this course we only consider the dc-dc converters operated in CCM.

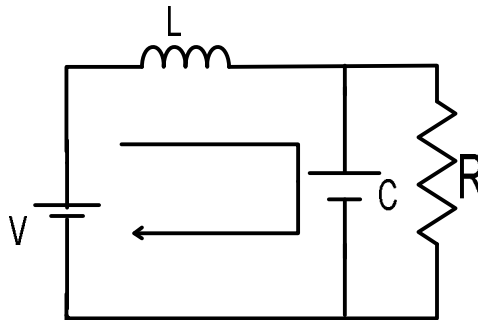


Figure 4. Boost converter during switch OFF time

### THREE PHASE INVERTER AND CONTROL SCHEME

An inverter is a circuit that converts DC sources to AC sources. Inverters are utilized in a ample variety of applications from undersized switched power supplies for a computer to huge electric utility applications to transport bulk power. This makes them very suitable for when you need to use AC power tools or appliances. Power inverters produce one of three different types of wave output:

- Square Wave
- Modified Square Wave (Modified Sine Wave)
- Pure Sine Wave (True Sine Wave)

In photovoltaic system, the DC/AC inverter is used to convert the power of the source by switching the DC input voltage in a pre-determined sequence to generate AC voltage output. Equivalent circuit of three-phase inverter is shown below. It has six switches that turn on and off to obtain a sinusoidal output. Pulse Width Modulation is a technique that is used as a way to decrease harmonic content in the inverter circuit. The supply of an induction motor by the solar generator requires the use of an inverter which transforms the DC-voltage into a three phase AC-system with variable frequency and voltage. There are two basic types of forced-commutated inverter: The current source inverter and the voltage source inverter. This chapter is focused on detailed study and modeling of three phase inverter as a frequency changer modulated by Sinusoidal Pulse Width Modulation (SPWM).

### The 180 Degree Mode Voltage Source Inverter:

The DC voltage obtained from the PV array is converted to AC voltage with the help of inverter. A voltage source inverter provides a firm link voltage across the motor terminals. While the load current adjusts itself according to the impedance of the motor. Here six-step 180 degree mode inverter is used to obtain a three-phase voltage output from DC source. The prime reason behind using a six-step inverter is only to minimize the switching losses since the phase voltage in this case is a six-step wave. Three-phase voltage source inverter is a combination of three single-phase bridge circuits. A simplified diagram of a basic three-phase inverter bridge is shown in figure 6. There are diodes in anti parallel in addition to the main power devices. These diodes are called the return current or feedback diodes. It provides an alternate path for the inductive current.

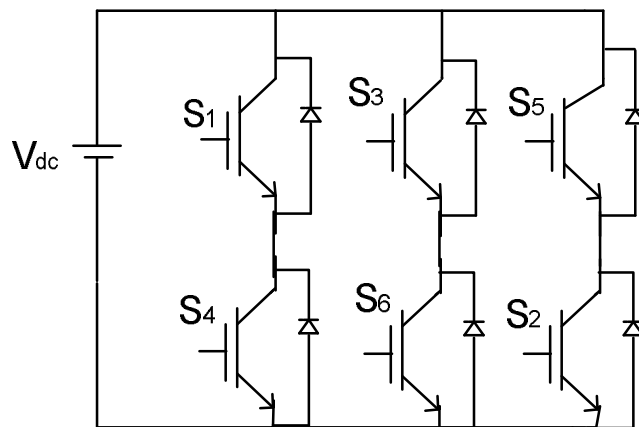


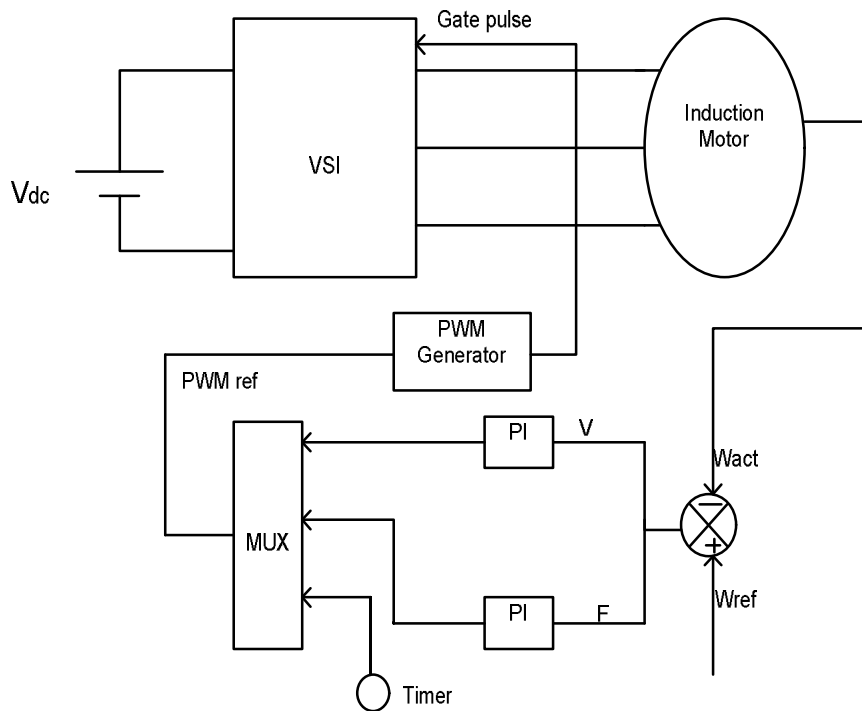
Figure 5. Three-Phase Six-Step Inverter.

To obtain the three-phase AC current in six-step inverter, six gating signals need to be applied to the six switches of the inverter. The waveforms of gating signals H1, H3 and H5 are shown in figure 5. H1, H3, H5 are 3 phase symmetrical switching function with phase shift  $120^\circ$ . To produce the symmetrical three phase voltages across a three phase load the devices are switched ON for  $180^\circ$ . The switching signals of each inverter leg are displaced by  $120^\circ$  with respect to the adjacent legs. The switching signals S1 and S4 are complementary, the same for S3 and S6, S5 and S2. The switching sequence will be S1S2S3, S2S3S4, S3S4S5, S4S5S6, S5S6S1, S6S1S2, S1S2S3 ... for a positive sequence. The sequence will be reversed to get the negative phase sequence. The line to neutral voltages  $V_{an}$  represented the six step of the inverter.  $V_{bn}$  and  $V_{cn}$  have the same waveform with phase shift  $120^\circ$ . Each switch is turned ON for  $180^\circ$ . The switches S1 and S4, which belong to the leftmost inverter leg, produce the output voltage for phase A. The switching signals for the switches in the middle leg, S3 and S6 for phase B, and are delayed by  $120^\circ$  from those for S1 and S4 respectively for a positive sequence. Similarly, for the same phase sequence, the switching signals for switches S5 and S2 are delayed from the switching signals for S3 and S6 by  $120^\circ$ . During step 1,  $0 \leq \omega t < 60$ , IGBT5, IGBT6 and IGBT1 are conducting.

### INDUCTION MOTOR (IM)

Induction motor is an electrical to mechanical conversion device and it is an asynchronous AC machine because the rotor speed is always less than the stator magnetic speed [4]. The construction of IM is rugged and cheap therefore it is widely used in many applications like in elevators, water pumping system and in industries. The frequency of the stator voltage controls the synchronous speed. The speed control of IM is possible by controlling the frequency, by changing the number of rotor poles, by changing the slip, by injecting the emf in phase or out of phase with the rotor induced emf etc. in this paper the output of PV system fed to the boost converter, this converter increase voltage level and fed to 3-ph

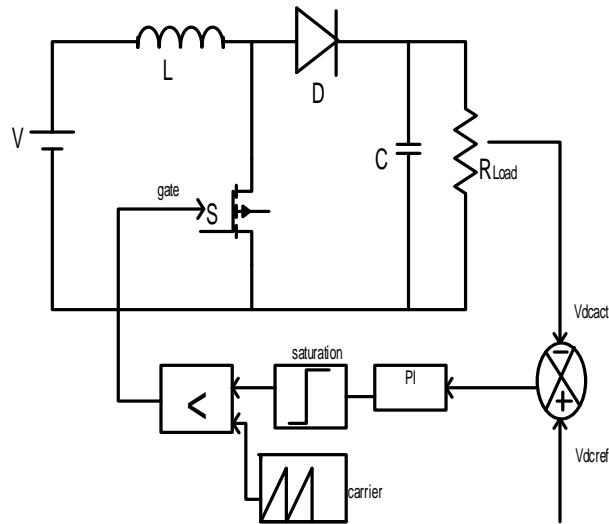
inverter, SVPWM is used to control the output of the inverter and is fed to induction motor. Here the speed of the induction motor is controlled with the help of closed loop controller. PI controller is used to reduce the steady state error without effecting the stability hence the speed is regulated at a desired point. G. Control Strategy of Induction Motor: SVPWM technique is use in this paper to control the induction motor in a closed loop manner. The advantage of this closed loop controlling is based on output speed, the frequency and amplitude of the reference signals will change [2]-[3]. V/f ration of IM is kept constant In order to continue constant magnetic. PI controller is used in a closed loop to regulate the speed of the motor and also reduce the steady state error. The error signal is generated in a closed loop system by comparing actual speed of the motor with the reference speed. Difference between the actual and desired speed gives the amplitude and polarity of the error signal. To overcome this generated error signal, the PI controller generates the corrected stator frequency of IM [4].



**Figure 6.** Pv based Induction motor drive controlling at by v/f technique

## BOOST CONVERTER CLOSED LOOP

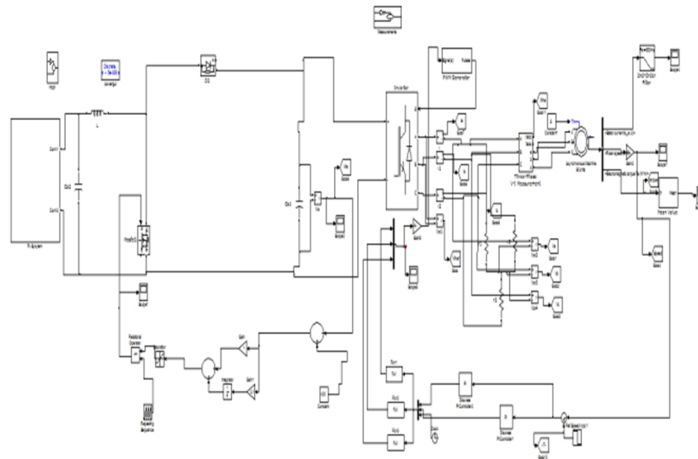
In a boost converter, the output voltage is all the time superior than the input voltage. When the switch is closed, current flows through the inductor in clockwise direction and the inductor supplies the energy. When the switch is opened, current will be abridged as the impedance is advanced. Therefore, change or reduction in current will be opposed by the inductor. Block diagram of closed loop boost converter is shown in fig7. As in fig 7 the major principle that drives the boost converter is the susceptibility of an inductor to acknowledge changes in current. As a outcome two sources will be in series routing a higher voltage to charge the capacitor through the diode. If the switch is cycled quick sufficient, the inductor will not set free fully in between charging stages, and the load will forever see a voltage better than that of the input source only when the switch is opened. Also while the switch is opened, the capacitor in parallel with the load is charged to this collective voltage. When the switch is then closed and the right hand side is shorted out from the left hand side, as a result the capacitor able to afford the voltage and energy to the load. During this time, the blocking diode avoids the capacitor from discharging through the switch. The switch must of course be opened yet again fast enough to put off the capacitor from discharging too much. The output of boost converter is fed to the common of power transistor and pulse is given to the base. The output pulse of power transistor is obtained from emitter which is of the amplitude with respect to the output dc voltage of boost converter fed to the common of transistor. The output pulse of the power transistor is fed to the integrator circuit where the pulse is integrated to give a ramp signal. This pulse is given to the switch of the boost converter and thus it completes a closed loop. Duty ratio of the pulse that is fed to the switch of boost converter is varied by the varying the DC voltage that is being compared in the comparator circuit with the output ramp signal of the integrator circuit.



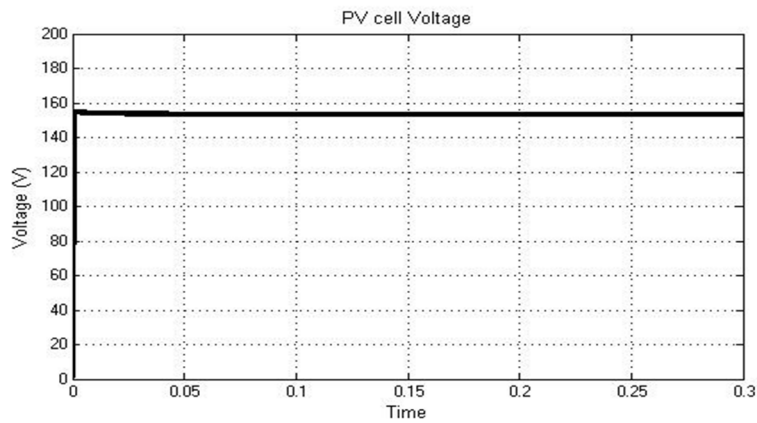
**Figure 7.** Block diagram of closed loop boost converter

**MATLAB/SIMULINK RESULTS**

Case 1: PV based Induction motor drive controlling at fixed speed by v/f technique

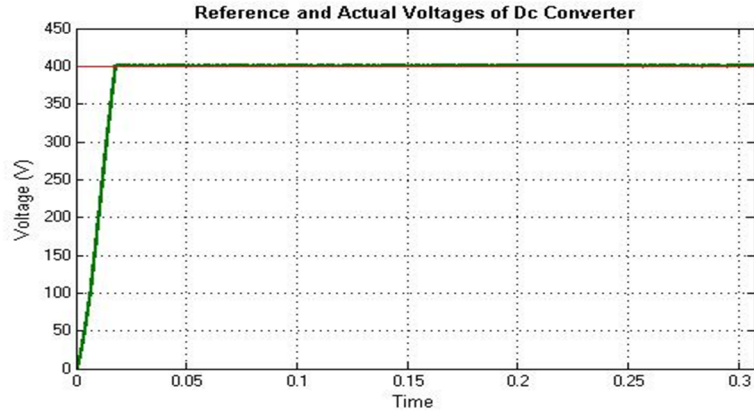


**Figure 8.** Simulink model of Pv based Induction motor drive controlling at Fixed speed by v/f technique

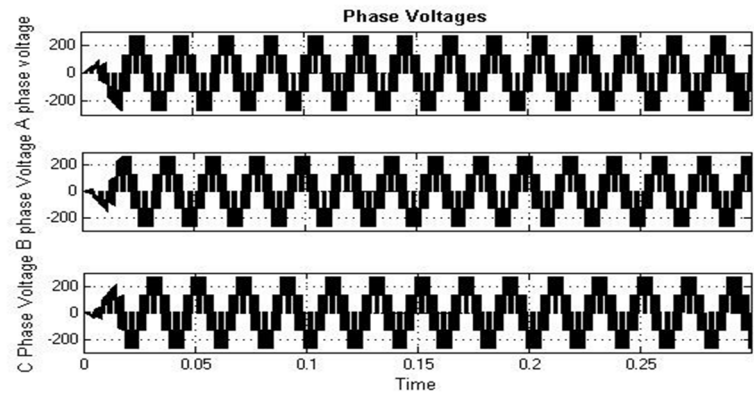


**Figure 9.** Simulated output voltage wave form of PV Cell

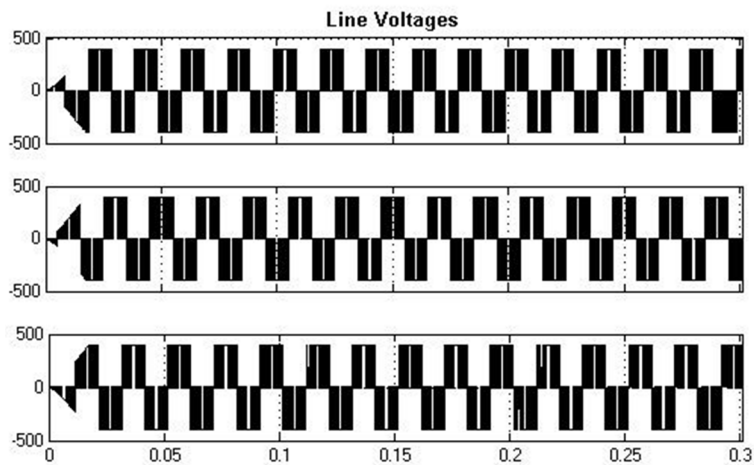
In below figure it shows that the Voltage from PV cell has been boosted to 400v by using Closed loop controlled Dc-Dc Converter



**Figure 10.** Simulated output voltage wave form of Reference and Actual Voltages of the Dc-Dc converter

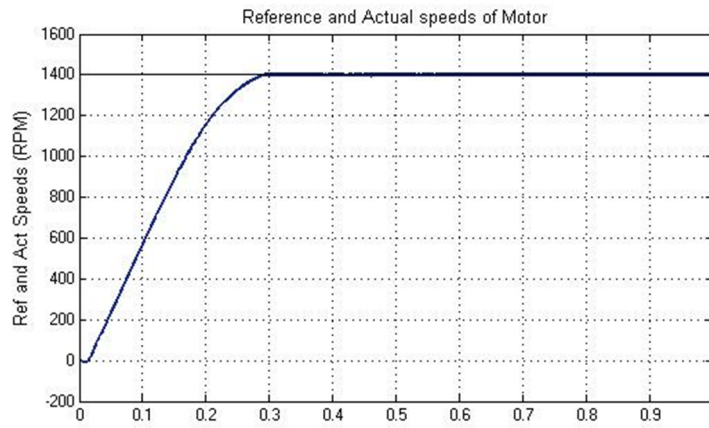


**Figure 11.** Simulated phase voltage wave forms of the Voltage Source Inverter



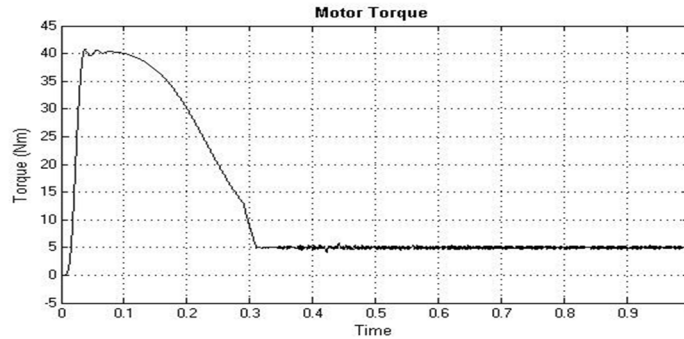
**Figure 12.** Simulated Line voltage wave forms of the Voltage Source Inverter

In the below figure it shows Motor running at 1400 rpm at fixed speed accurately as given as the reference speed due the efficient v/f closed loop control technique.



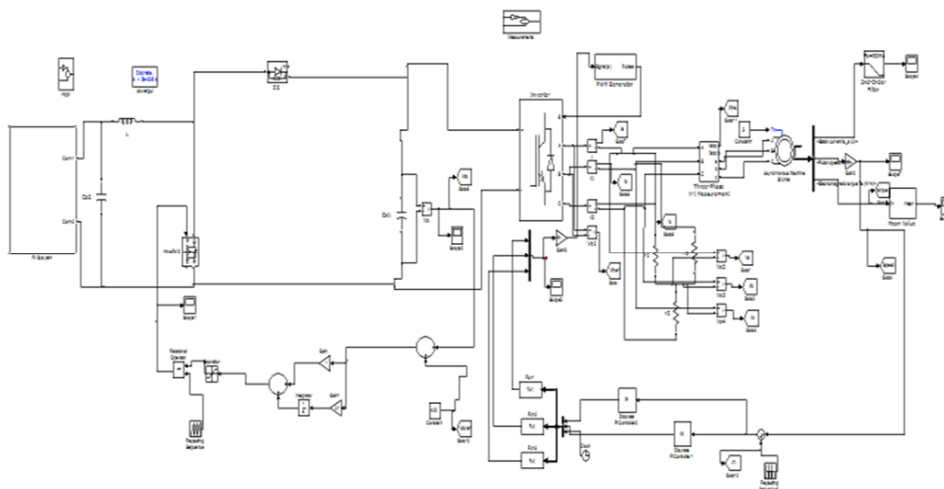
**Figure 13.** Simulated Reference and actual speed wave forms of the v/f controlled VSI fed Induction motor drive

In the below figure it shows at initial conditions, motor draws high torque and final reaches to 5Nm at steady state conditions as the load torque TL given.



**Figure 14.** Simulated output wave form of the Induction motor Torque at fixed speed

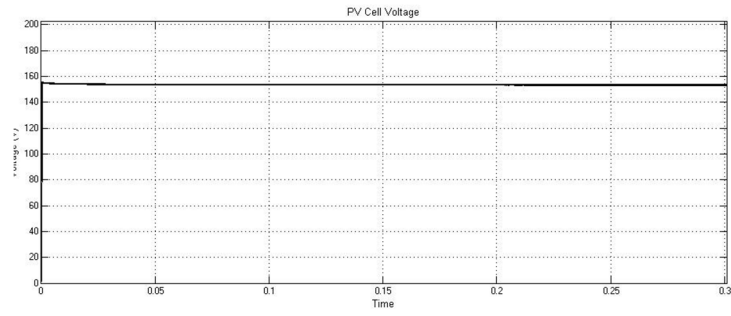
Case 2: PV based Induction motor drive controlling at variable speed by v/f technique



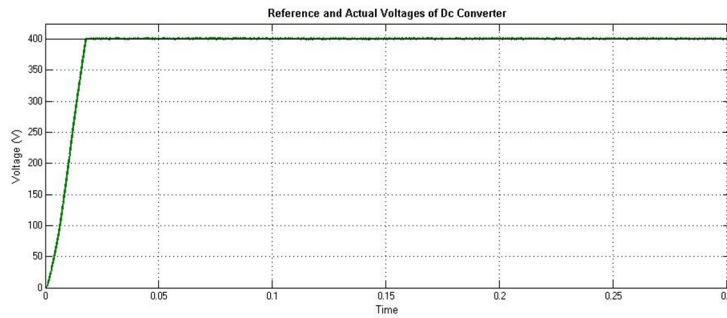
**Figure 15.** Simulink model of Pv based Induction motor drive controlling at variable speed by v/f technique

In below figure it shows that the Voltage from PV cell has been boosted to 400v by using Closed loop controlled Dc-Dc Converter

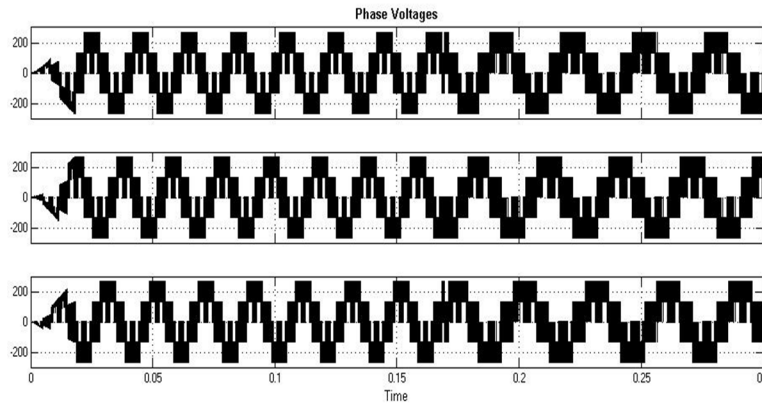




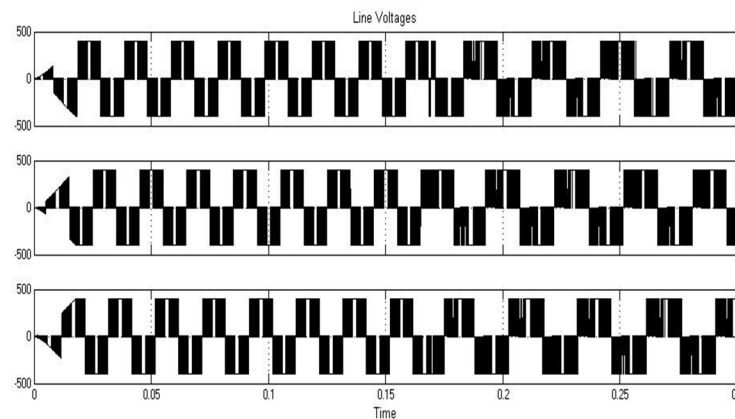
**Figure 16.** Simulated output voltage wave form of PV Cell



**Figure17.** Simulated output voltage wave form of Reference and Actual Voltages of the Dc-Dc converter

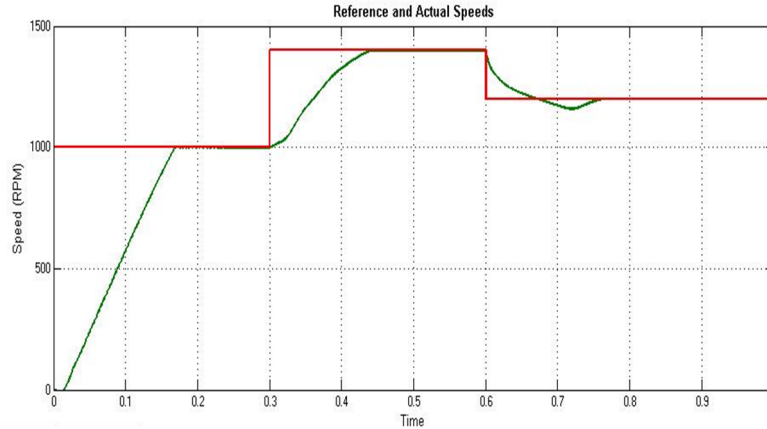


**Figure 18.** Simulated phase voltage wave forms of the Voltage Source Inverter



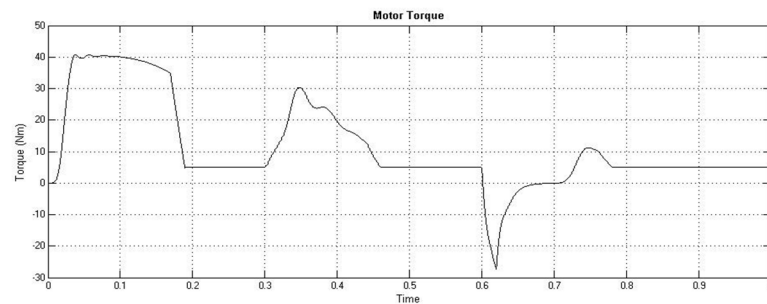
**Figure 19.** Simulated Line voltage wave forms of the Voltage Source Inverter

In the below figure it shows Motor running at 1000 rpm upto 0.3secs, 1400 rpm upto 0.6secs and 1200 rpm with Variable speed accurately as given as the reference speed due the efficient v/f closed loop control technique



**Figure 20.** Simulated Reference and actual speed wave forms of the v/f controlled VSI fed Induction motor drive

In the below figure it shows at initial conditions, motor draws high torque and final reaches to 5Nm at Steady state conditions as the load torque TL given.



**Figure 21.** Simulated output wave form of the Induction motor Torque at variable speed

## CONCLUSION

The proposed concept has been implemented with v/f technique for the inverter with PV as the source. The advantage of the proposed control technique is controlling the Induction motor at variable speed conditions with high response and minimum steady state error. In order to obtain the efficient performance characteristics of the motor a closed loop technique has been proposed and its feasibility is analyzed by Simulink results and shown.

## REFERENCES

- F. Z. Peng, Z. Qian and F. Zhang, "A magnetic-less DC-DC converter for dual-voltage automotive systems," IEEE Trans. Ind. Applications, vol. 39, no. 2, pp. 511-518, (Mar. 2003).
- Y. Liu, N. Liang, and W. Li, G. Ma, W. Qu and G. Yu, , "A zero-voltage switching bidirectional DC-DC converter with state analysis and soft switching- oriented design consideration," IEEE Trans. Ind. Electron., vol. 56, no. 6, pp. 2174-2184, (Jun. 2009).
- Hui Li, J. S. Lawler, F. Z. Peng and G. J. Su, "A new ZVS bidirectional DC-DC converter for PV cell and battery application," IEEE Trans. Power Electron., vol. 19, no. 1, pp. 54-65, (Jan. 2004).
- Gautam Poddar and Suvajit Mukherjee "A Series-Connected Three-Level Inverter Topology for Medium-Voltage Squirrel-Cage Motor Drive Applications" Ieee Transactions On Industry Applications, Vol. 46, No. 1, (January/February 2010).
- T. Abe, and H. Akagi, N. M. L. Tan, "Design and performance of a bidirectional isolated DC-DC converter for a battery energy storage system," IEEE Trans. Power Electron., vol. 27, no. 3, pp. 1237-1248, (Mar. 2012).